

EVL16A-A

EV Traction Dry Cell Industrial Battery Block

Discover® EV Series Industrial Batteries provide superior high integrity and reliability for commercial, industrial and private applications. The maintenance-free, thick plate construction, designed for tough applications and repeated deep discharging makes the EV Series the definitive choice for robust Traction applications including Home Medical Equipment (HME), Electric Vehicle, Automated Guided Vehicles (AGV), Aerial Lifts, Floor Cleaning Equipment, Robotics, Materials Handling, Renewable Energy and Marine / RV applications.

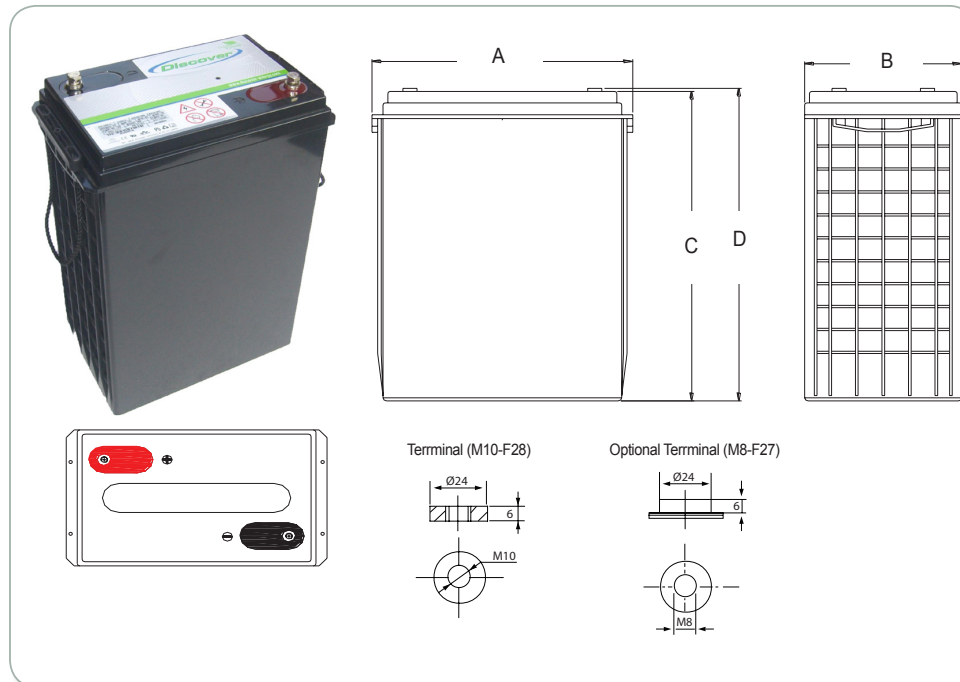

Mechanical Specifications

Industry Reference	903-L16	
Length [A]	11.6 in	295 mm
Width [B]	7.1 in	180 mm
Height [C]	16.0 in	406 mm
Total Height [D]	16.8 in	426 mm
Weight	121 lbs	55 kgs
Terminal (Opt'l)	M10-F28 (M8-F27)	
Terminal Torque NM	7.0-7.7 (9.5-10.5)	
Cells	3 cell	
Electrolyte	1.2875 S.G.	AGM

Electrical Specifications

Volts	6 V	
80% DOD Voltage Cutoff	5.7 V	
RINT	1.7 mOhms	
Short Circuit (68° F / 20° C)	3250A	
Self Discharge	<3% of capacity month @ 68° F / 20° C	
Cranking Amps*	1485 @ 32° F / 0° C	1235 @ 0° F / -18° C
Standard Charge	50° F / -10° C to 122° F / 50° C	
Standard Discharge	-4° F / -20° C to 122° F / 50° C	
Maximum Discharge**	-40° F / -40° C to 140° F / 60° C	

*CRANKING AMPS: Cranking Amps data is provided as a reference only. Specific application sizing and life factors must be considered when using deep cycle product in a starting application.

**CAUTION: Extra considerations must be given to depths of discharge, operating voltages and currents when designing systems for use at maximum temperatures.

Electrical Specifications

Amp Hours (AH)						Minutes of Discharge				
100HR	20HR	10HR	5HR	3HR	1HR	@25A	@56A	@75A	@85A	@100A
438	390	365	335	290	240	915	375	265	235	190

Max Charge / Discharge Currents	Peak (5 seconds)	Peak (10 seconds)	Max Continuous	Recommended Max Continuous
Charge	1C10Hr	0.75C10Hr	0.5C10Hr	0.3C10Hr
Discharge	2C10Hr	1.5C10Hr	1C10Hr	0.5C10Hr

Updated April 30 2014

EV Series Features & Benefits

- Maintenance Free Clean & Green® choice of Original Equipment Manufacturers.
- Traction heavy duty grid design (PbCaSn) gives consistent active material adhesion and corrosion resistance.
- High impact reinforced copolymer and polypropylene cases with flat top designs.
- A recognized gas recombination efficiency of greater than 99.9%.
- Multiple terminal, configuration options and carrying handles available with most models.
- Classified as a non-spillable battery and is not restricted for transportation by:
 - Air (IATA/ICAO provision 67)
 - Surface (DOT-CFR-HMR49)
 - Water (per IMDG amendment 27).
- Compatible with sensitive electronic equipment.
- Comprehensive design to conserve resources, improve safety and reduce waste. 98% recyclable.

Certifications and Standards

Designed in accordance with and published in compliance with applicable BCI, IEC and BS EN standards, including:

- IEC60896-21/22
- BS EN 60254-1:2005
- AS/NZS 4029.2:2000 BS EN 60254-1:2005 (MOD).

Discover® and its facilities and products are certified to multiple standards:

- ISO, UL, QS, and TUV standards
- ETTS Germany
- Euro Bat classification for Environmental Stewardship Standards.



Contact Us

Discover Energy Corp.
 Suite 880-999 West Broadway
 Vancouver BC V5Z 1K5 Canada
 Tel: 604.730.2877
 Email: info@discover-energy.com
www.discover-energy.com

Graphs

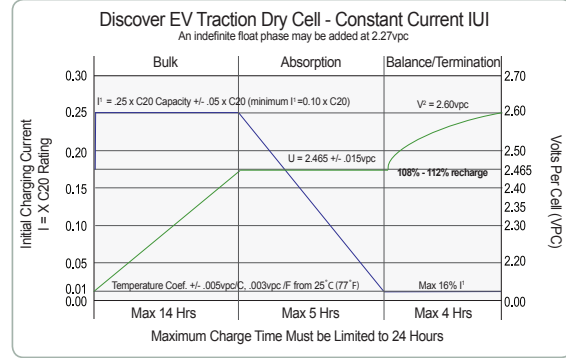
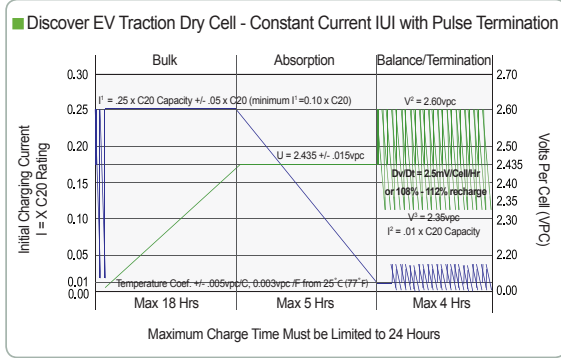

NOTE: This algorithm uses a pulse termination criterion. As a safety precaution during the Finish phase, if the average cell voltage, or volts per cell (vpc), exceeds V2 and the charger output has been on for more than 30 seconds, the output is shut off until the vpc falls to V3. The finish phase then resumes and this "pulsing" continues until the target overcharge (108% - 112%) is reached.

